

THE IDEA IS BORN

Sherpa is one of the major ethnic groups of the Himalayas. Sherpas are renowned for their endurance at high altitudes and their general reliability under rough conditions. They can easily navigate the mountains and are indispensable guides and mentors for climbers.



Sergey Samokhvalov, one of the co-founders of the SHERP Company, is originally from the Taiga. For more than 20 years, he has been in the business of gas pipe maintenance and has travelled and explored the region. During one of his numerous expeditions, he met **Vladimir Shkolnik**, who introduced him to Alexei Garagashian, an engineer and inventor. Alexei showed Sergey one of his works: it was the first prototype of the SHERP UTV.

Having tried almost everything from the world of four-wheel drive vehicles, together they had been searching for an ultimate UTV that could be used to go fishing and hunting, as well as travelling to any uncharted territory. All the participants of their first expedition were so surprised by SHERP's operating capabilities on off-road terrain and the ease of control that they decided to work on the prototype to create a market-ready vehicle suitable for any conditions.

SHERP IS A PIONEER AND A WORLD LEADER ON THE UTVS MARKET

SHERP is an export-oriented company, originally based in Kyiv, Ukraine, is the developer and manufacturer of the **SHERP utility terrain vehicles** that has no analogs in the world in terms of its capabilities and characteristics.

The SHERP factory in Kiev was opened in 2015 and nowadays it provides a full cycle of machine building and has own Research and Development department.

The company has international quality standards certificate **ISO 9001** and is covered by **patents in more than 100 countries** all over the world.

The first SHERP UTV was produced and presented in 2012. As of today the model range consists of series-produced models and customized solutions.

SHERP UTVs are capable of being used on **any type of terrain**, overcoming obstacles and being able to float on water.



INNOVATIONS & TECHNOLOGIES



Security

SHERP's body construction includes internal integrated ROPS (rollover protection system) made of steel, making the UVT much more secure in case of rollover.

Tubeless ultra-low pressure tires

Boasting impressive strength and durability, they remain lightweight and elastic. The tires feature a high level of adhesion to the ground and enable movement on water.



Fuel tanks in the wheels

SHERP has 58 L fuel tanks integrated in each of the wheel disks, that essentially increases the UTV's autonomy, while the internal compartment remains available for tools / equipment storage.

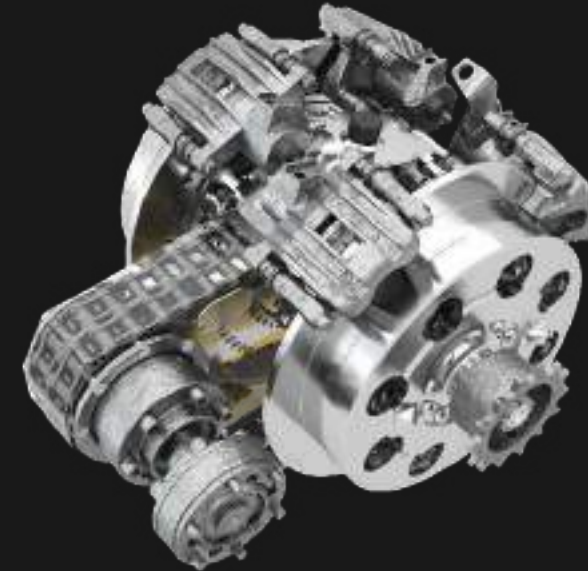

Skid steering

SHERP's friction mechanism makes turning easier. It is equipped with a hydraulic steering system, making maneuvering effortless with the reliable and simple turning mechanism.

Pneumocirculating suspension

A unique patented solution that ensures the smooth and even movement of the UTV on any surface. The suspension design does not include any conventional elements, resulting in fewer parts, higher reliability, fewer breakdowns, lower repair costs.

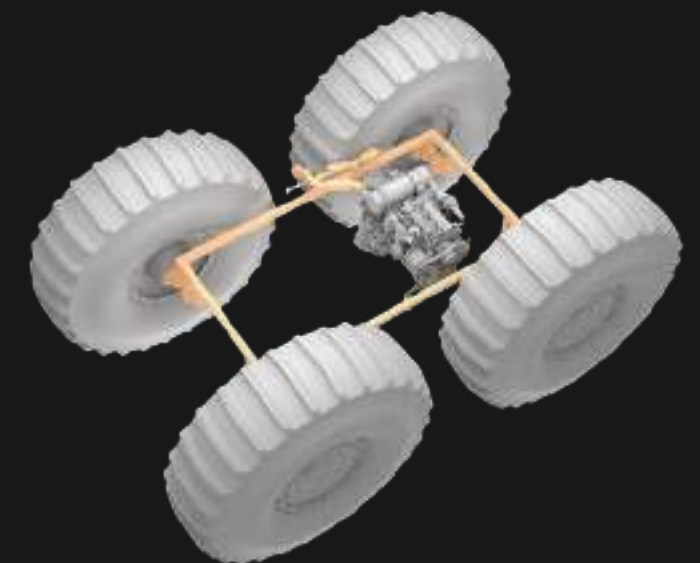

OUR HISTORY



THE FIRST SHERP ALL-TERRAIN VEHICLE WAS PRESENTED TO THE WORLD.



IN 2015 THE SHERP FACTORY WAS OPENED IN KYIV, UKRAINE.



IN 2016 THE BRITISH MOTORING SHOW, TOP GEAR, REFERRED TO SHERP AS A "TANK FOR TWO."



IN 2017 SHERP OPENED ITS NORTH AMERICAN OFFICE IN WINNIPEG, CANADA.



LAUNCH OF THE SHERP PRO.



2018 SHERP BECAME AN OFFICIAL SUPPLIER FOR UNITED NATION.



IN 2019 SHERP WAS RECOGNIZED AS THE MOST EFFECTIVE VEHICLE FOR THE UN BY THE FLEET AWARDS.



2019 - INTRODUCTION OF SHERP THE ARK AND SHERP THE SHUTTLE.



2020 - LAUNCH OF SHERP N.



IN 2020 SHERP INTRODUCED RENTAL SOLUTION INITIATIVE.



IN 2020 SHERP LAUNCHED FUN BUSINESS.



2020 SHERP SET UP A DISTRIBUTION CONTRACT WITH WORLD LEADING MANUFACTURER OF ATVs IN THE NORTH AMERICA - ARGO.

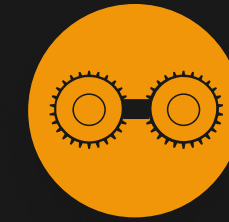

2021 INTRODUCTION OF SHERP UGV PLATFORM.



2021 SHERP OPENED AN OFFICIAL DISTRIBUTOR IN THE UAE - MAPOS.



2022 UKRAINE IS INVADED BY RUSSIAN FEDERATION

CURRENT SHERP FACTORY

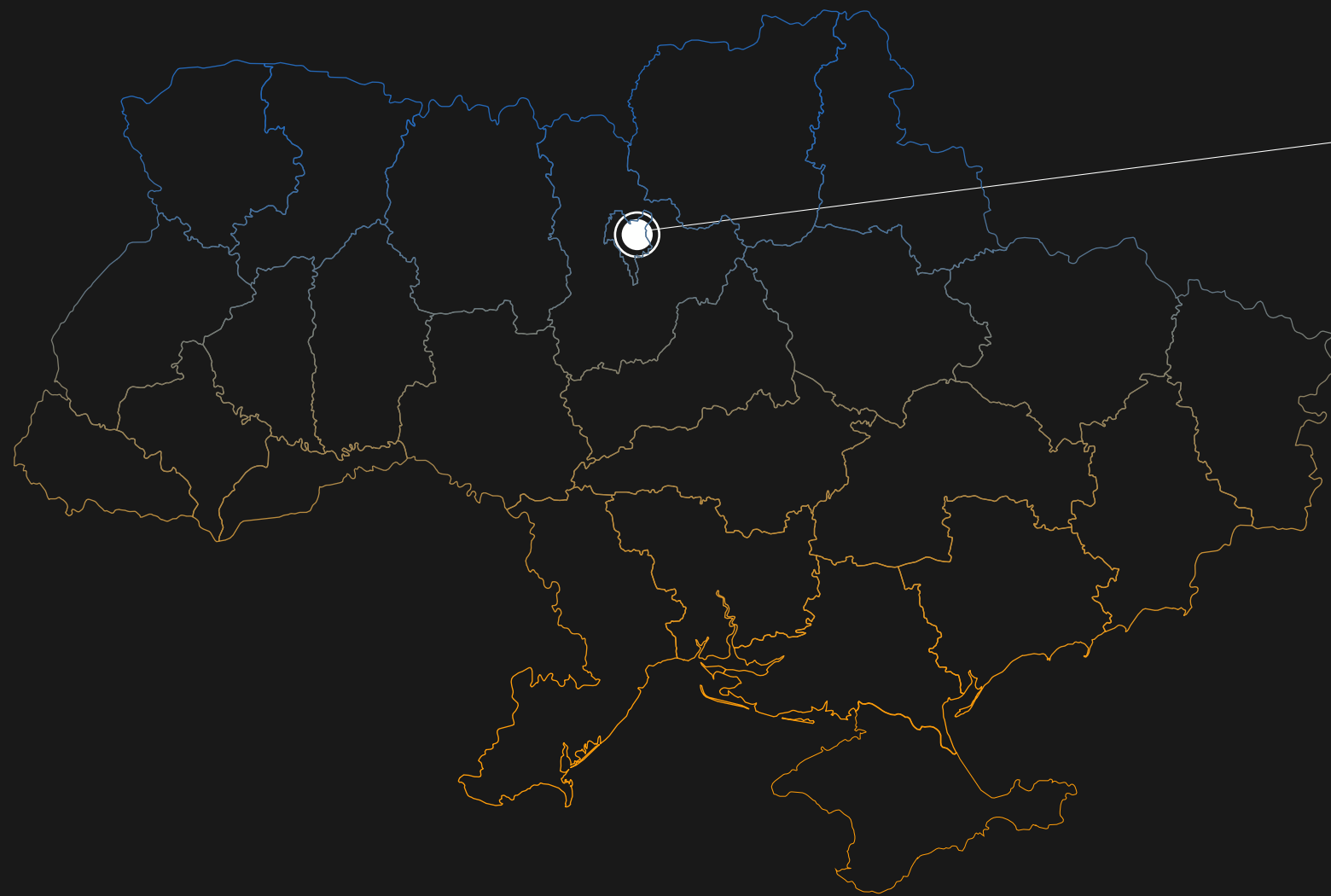

ADDRESS	STOLYCHNE SHOSE, 100 03026, KYIV, UKRAINE
LOCATION	VIEW ON THE MAP
AREA	6.500 SQ.M
PERSONNEL	200 PEOPLE

WE PROVIDE A FULL CYCLE OF MACHINE BUILDING



Welding on steel and aluminum, brazing of plastic structures, heat treatment.



Turning, grinding, cutting laser and bench working of parts.



Stamping and bending of metal parts, molding of ABS plastic and low-pressure polyethylene.



Painting, including full pre-treatment self-adhesive film coating.



Designing, shaping and cutting of parts from metal, plastic and plywood.



Assembly of units and structures of the UTVs.

RELIABLE SUPPLIERS

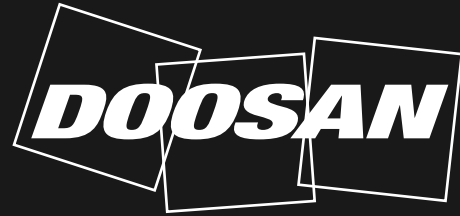

The heart of SHERP Search & Rescue UTV is the high-technology Doosan engine (Korea), that provides high torque and fuel efficiency with a low level of noise and vibration. The engine is adapted for work in any climate zone.

Doosan Infracore is a world-class engine manufacturer with subsidiaries all around the world. Doosan engines are widely used for construction equipment, agricultural machinery, power generators, etc.



The UTV's exterior coating is Raptor polyurethane paint. This type of coating has soundproof and water repellent properties. The "Raptor" professional paint protects against mechanical damage, corrosion, mold, chemical exposure (fuel, machine oil).



SHERP's parts are made from DOCOL steel, which is resistant to deformation due to its high yield strength (1000 MPa), which indicates its strength and resistance to deformation. All parts of the mechanism have a zinc coating, which extends the SHERP's service life by 30 years.

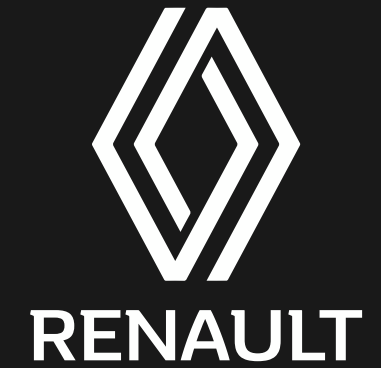

The transmission is equipped with a RENAULT manual gearbox, which has shown its best qualities in terms of reliability, smooth shifting and gear ratios.

SHERP TEAM

By locating the plant in Kiev, Ukraine, in 2015, the company has attracted leading engineers and talented specialists to build up effective business processes and create the future of SHERP.



VOLODYMYR SHKOLNIK
SERHII SAMOKHVALOV

SHAREHOLDERS

R&D

- Design
- Assembly
- Warehouse

QUALITY CONTROL

- Quality engineers
- Quality inspectors

CEO

VIKTORIIA TVERDOKHLIB

ADMINISTRATION

- Business Development
- IT
- HR
- Legal
- Training

SALES & MARKETING

- Sales Development
- Disposition
- Marketing

FINANCE

- Business Analytics
- Accounting

AFTER-SALES

- Service
- Spare parts
- Service warehouse
- Planning & Dispatching

PRODUCTION

- Planning & Dispatching
- Production Engineering Office
- Design Office
- Mechanical Office
- Procurement
- Logistics
- Warehouse

CUSTOMERS' PORTFOLIO

SHERP UTV has a wide range of application throughout the world. That is why we keep on moving further to expand our product to all continents and find partners all over the world.

SHERP UTV is an effective business solution that helps its customers to eliminate their pain points and save costs. Therefore 90% of the customers are non-governmental organizations and B2B and B2G segments in a variety of industries: mining & exploration, oil & gas, telecom, powerlines, construction, search & rescue, humanitarian.

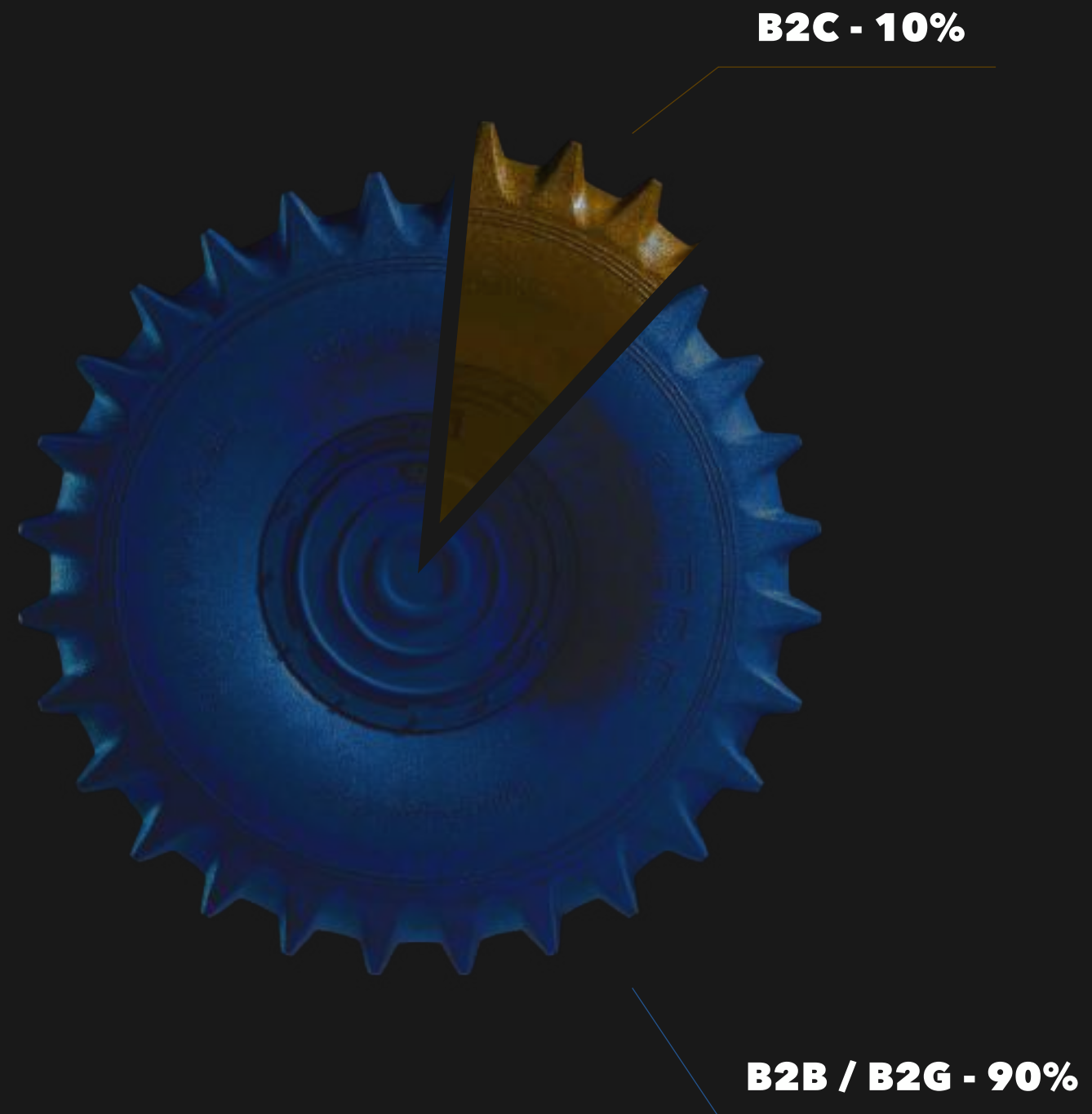



POWERLINES

Energy companies which produce / deliver energy, power generation and infrastructure management.

SHERP Solution

Support unit for power-grids repair and maintenance operations at hard-to-reach areas and harsh terrain. It allows to restore power supply faster and decrease down-times. Safe and suitable for energy infrastructure servicing.



CONSTRUCTION

Companies involved in real estate development, construction and dredging work in hard-to-reach areas, remote constructions of private equity and public infrastructure.

SHERP Solution

Helps to deliver equipment and personnel to remote areas:

- The only UTV that rides and climbs on the thin ice and high shores
- Carries heavy cargos on the off-road
- Cheaper owning comparing to a truck
- Any-weather transportation





MINING & EXPLORATION

Geo-exploration, surveying and mining.

SHERP Solution

- Can be used in winter, flooding periods or at the peat bogs.
- Able to carry heavy equipment and cargo on the off-road.
- Autonomous - due to additional fuel tanks integrated in each of the wheel disks, as well as low fuel consumption.
- Up to 5 sleeping places in 1 four-wheel SHERP.
- Maintenance-friendly, so it can be repaired at any place, no matter the outside environment.



OIL & GAS

Pipelines and rigs maintenance companies who are involved in mining, mineral processing pipelines, rigs maintenance and transportation.

SHERP Solution

- Significantly decreases time for maintenance, crew transportation and reduces pipelines down-time regardless of weather conditions
- Safe and suitable for energy infrastructure servicing
- Able for any transportation on any terrain: swamps, water, any kind of soils, thin ice





SEARCH & RESCUE

Emergency services, search & rescue operations, all-kind of organizations protecting and saving people: fire departments, humanitarian missions, local S&R agencies etc.

SHERP Solution

Rescue people from the flooded areas, airplane crash recovery, rescue operations on ice. Multipurpose vehicle that can replace several types of vehicles (for example, boat, helicopter and light UTV), extremely versatile for any type of equipment and has a buoyant body.



HUMANITARIAN

Humanitarian organizations and missions, which are involved in supply activities, providing medical and healthcare, mobile treatment in hard-to-reach locations.

SHERP Solution

Allows to deliver people and cargo (medical supplies, food and water, construction supplies etc.) to the remote locations regardless of the terrain or weather conditions:

- High effectiveness of humanitarian aid transportation, allowing to reach target locations.
- Transportation costs reduction by switching to SHERPs from aerial transportation in humanitarian missions



Use cases



RENTALS

Sherp Rentals is a solution for a single seasonal project as well as long-term projects. We understand how remote and difficult that work can be, and this is why there is a rental opportunity that meets the needs and requirements of any company or organization in order to achieve their goals.



RECREATION

SHERP off-road capabilities were appreciated not only by businesses and municipal services but also by outdoor enthusiasts. Fishermans, hunters, travelers, and off-roaders around the world rely on the phenomenal utility-terrain vehicle and autonomy of SHERP beyond civilization.



34 DEALERS
15 COUNTRIES



In 2020 SHERP set up a Distribution contract with world leading manufacturer of ATVs in the North America - ARGO.



SHERP is the official supplier of the United Nations' World Food Programme.

WFP won the 2019 Best Transport Achievement Award for the SHERP project.







SHERP solution for the United Nations:

- 75% reduction in transportation cost
- USD 1.7m saved by replacing airfreight







COMPANY DEVELOPMENT VECTOR



OUR STRENGTHS

-  We are global
-  Product leadership
-  Innovations & technology
-  Customized approach
-  Experienced & talented team
-  Industrial & business profile

FURTHER DEVELOPMENT

-  Prominent quality upgrade
-  Customer service enhancement
-  Global marketing strategy
-  Development of new sales tools
-  Lean production
-  Dealership advancement
-  Search for new use cases

PRODUCT DEVELOPMENT IS OUR KEY PHYLOSOPHY



SHERP PRO
2017 - 2020



SHERP THE ARK
2019



SHERP N
2020



CUSTOMIZED SOLUTIONS
SEARCH & RESCUE
FIREFIGHTING
2021



SHERP UGV PLATFORM
2021



NEW SOLUTIONS
2023

SHERP N 1200



Due to its extra high passability, SHERP N is able to:

- Pass the most harsh terrains
- Overcome obstacles up to 1 m height. It's the only wheeled vehicle to climb from waters onto the ice.
- Float constantly at any depth
- Operate at a temperature range -40°C +45°C in the smoke, fog, rain, blizzard, hurricane, heat, and storms.



SHERP N is a utility terrain amphibious vehicle, designed to operate in extremely difficult conditions and any type of terrain, overcome multi-level obstacles and float on water.

Official manufacturer's warranty: 2 years or 1000 m/h. 24/7 customers' support all around the world.

SHERP N is reliable and maintenance-friendly, so it can be repaired at any place, no matter the outside environment.



SHERP N PICKUP

Rare compartment of the SHERP can be used both as cargo and passengers carrier.

The Pickup version has the removable body cover can be easily installed on the UTV so that the passengers or cargo are fully safe.

Service temperature

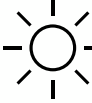
-40°C   +45°C

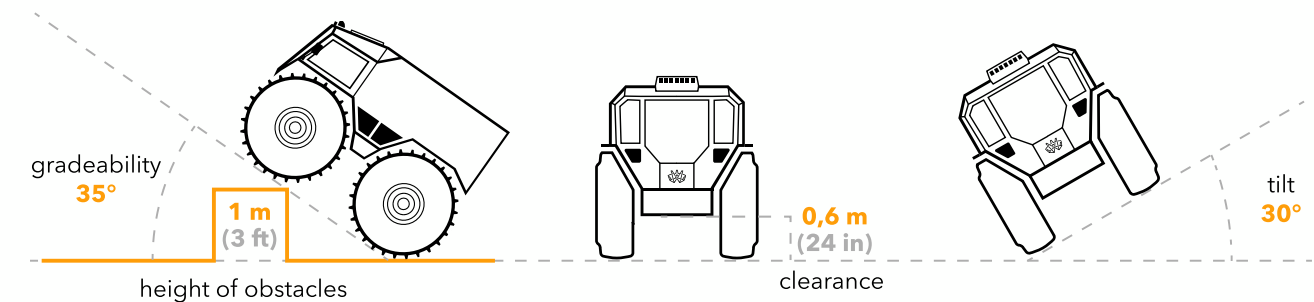

Overall dimensions

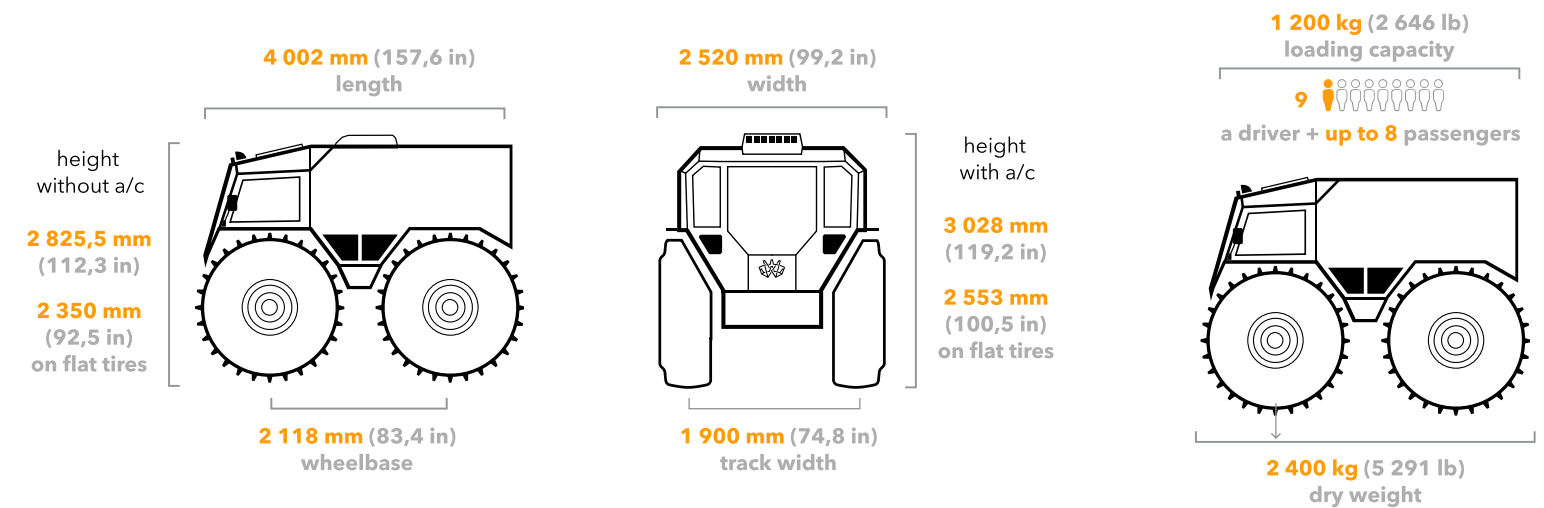

Fuel autonomy



DIESEL

95-327 L (25-86 gal)
5-8 lph (1,3-2,1 gph)

Fuel tank volume 95 L (25 gal)
4 wheel fuel canisters 58 L (15.3 gal) each
Up to 65 hours of autonomy and 19 hours of non-stop running with the main fuel tank.

Max. speed



Grounds

40 km/h
(25 mph)

dense forests, fallen trees, shaky grounds, gravel, peatbog, moor, marsh, dunes, swamps, boulders, scree, snow, ice



Water

6 km/h
(3,7 mph)

ponds, lakes, rivers, sandbanks, shelves, climbing from water onto the ice etc.

SHERP SEARCH & RESCUE UTV



For a **prompt response to emergencies** directly on the spot, Search & Rescue UTV can be equipped with emergency devices:

- Radio communication unit
- Special light and sound signaling devices
- LED stroboscopes with stainless steel protection
- LED searchlights with remote control
- LED rechargeable lights
- Protected low and high beam headlights



The best assistant in saving lives and delivering rescuers to the places of rescue operations where standard rescue vehicles, helicopters and other equipment cannot reach.

SHERP S&R does not need the roads, as well as fallen trees, stones, water reservoirs and other obstacles will not stop it. Moreover, it can be easily transported along the public roads with the help of trailer.



The **inner space** of the SHERP Search & Rescue UTV is organized so that the rescuers always have everything they need ready to hands:

- Rescue stretchers with helicopter fastening system for victims' transportation
- Life jackets
- Heat-resistant rescue rope
- Professional entrenching tool
- First-aid kit
- Fire extinguisher
- Space for auxiliary tools (in-floor)

Service temperature

-40°C ❄️ ☀️ **+45°C**

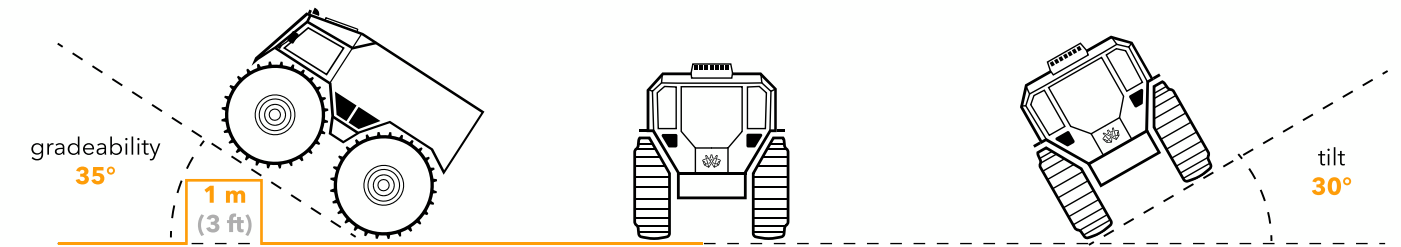

Overall dimensions

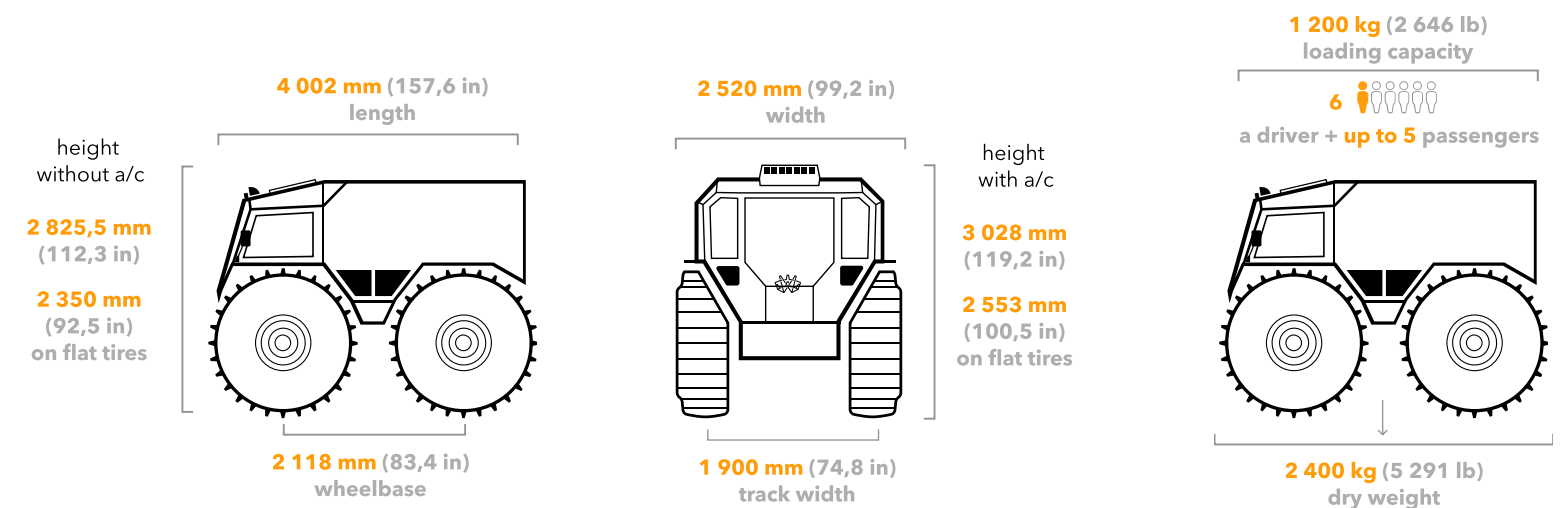

Fuel autonomy



95-327 L (25-86 gal)
5-8 lph (1,3-2,1 gph)

Fuel tank volume **95 L (25 gal)**
4 wheel fuel canisters **58 L (15.3 gal) each**
Up to **65 hours** of autonomy and **19 hours** of non-stop running with the main fuel tank.

Max. speed



Grounds

40 km/h (25 mph)

dense forests, fallen trees, shaky grounds, gravel, peatbog, moor, marsh, dunes, swamps, boulders, scree, snow, ice



Water

6 km/h (3,7 mph)

ponds, lakes, rivers, sandbanks, shelves, climbing from water onto the ice etc.

SHERP FIREFIGHTING UTV



Building of firelines

Speed up the procedure of setting up preventive firelines due to decreasing time for transportation of firefighters and the necessary equipment to the harsh terrain locations.

Direct and indirect firefighting attack

High effective firefighting' actions due to delivery of motorized and high-performance firefighting equipment in remote areas.

Creating a reliable resupply chain

Firefighting brigades receive fuel, water, and all necessary equipment on time despite complicated terrain or weather conditions.



The ultimate solution in fighting forest fires that take place in the most extreme conditions - non-flying weather, harsh terrains and poor visibility and that are inaccessible by other transport.



Effective fire mop-up procedure

The tire coolant system allows to move through smoldering areas and extinguish the embers to eliminate the possibility of fire renewal.

Eliminating flood aftermath

The UTV can be a high-performance movable water pumping unit for drainage workds during floods.

Search & Rescue operations

The UTV can be equipped with folding seats and stretchers to perform firefighters or casualties evacuation from a disaster area.

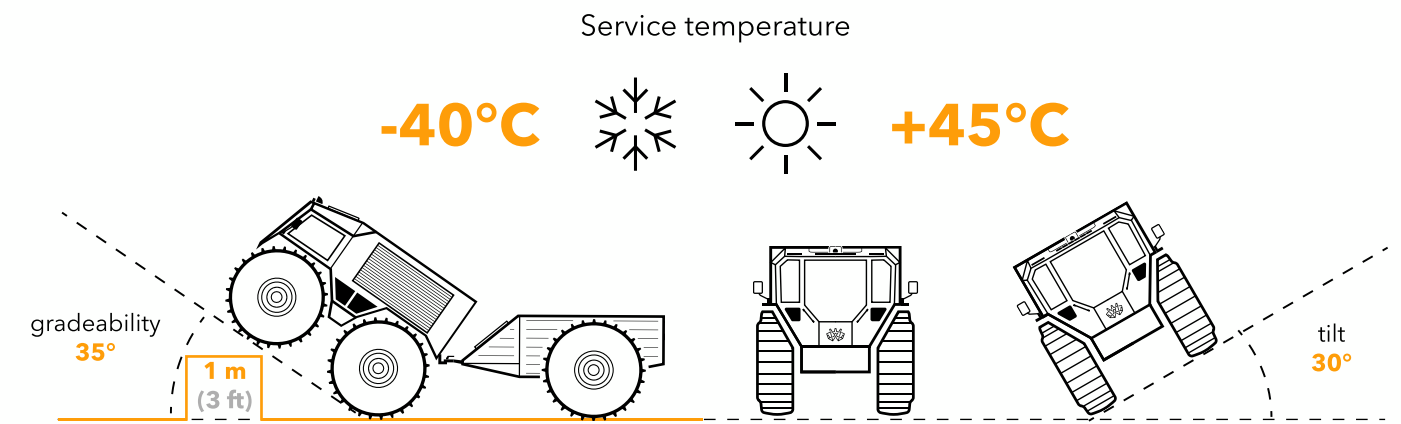

Overall dimensions

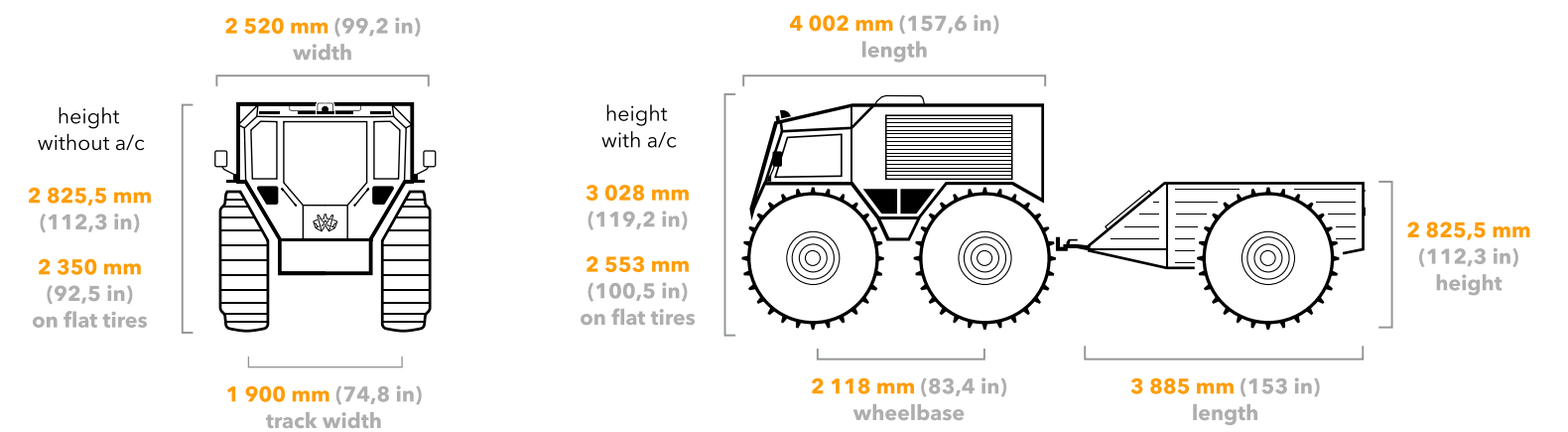

Fuel autonomy

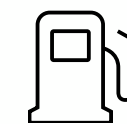

DIESEL

- 95-443 L (25-117 gal) UTV
- 95-327 L (25-86 gal) UTV + trailer
- 5-8 lph (1,3-2,1 gph) Fuel consumption
- 95 L (25 gal) Main fuel tank
- 58 L (15.3 gal) each: Additional fuel canisters:
 - 4 pcs • UTV
 - 2 pcs • trailer

Up to 65 hours of autonomy (88 hours when using a firefighting trailer) and 19 hours of non-stop running with the main fuel tank.

Loading / water capacity

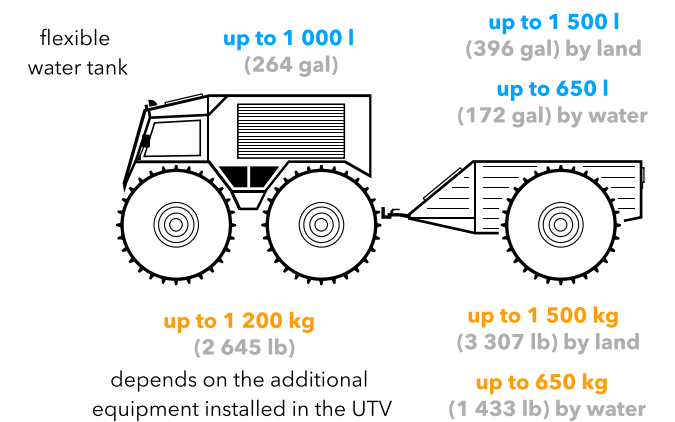

Max. speed



Grounds

40 km/h (25 mph)

dense forests, fallen trees, shaky grounds, gravel, peatbog, moor, marsh, dunes, swamps, boulders, scree, snow, ice



Water

6 km/h (3,7 mph)

ponds, lakes, rivers, sandbanks, shelves, climbing from water onto the ice etc.

UGV PLATFORM



Versatility and multi-purpose use

The design of the platform allows to install additional add-ons, that opens up possibilities of using UGV in a wide range of applications and tasks:

- extinguishing fires and fire hose laying
- rescue and transportation
- cargo transportation
- forestry (e.g. sowers and brush cutters)
- UAV support and launch
- border surveillance and military

Passability and maneuverability

UGV platform guarantees the best passability on the most difficult surfaces, where standard equipment simply cannot cope with obstacles.

Amphibious extremely high passability unmanned ground vehicle.

Durability and reliability

Smooth and even movement due to unique patented pneumatic circulation suspension. Ultra-low pressure tires allow to overcome any terrains and obstacles.

Autonomy and easy maintenance

User-friendly control panel, quick-change lithium batteries save time, so you can focus on the tasks accomplishment.



Remote control

- Platform guidance in all directions
- Inflating and deflating wheels
- Dump module's control
- Video monitoring while driving (incl. recording functions and night mode)
- Incline level display (inclinometer)
- Tracking the platform using GPS and displaying it on the map



Additional equipment

Dump module

Dump module weight

300 kg

Dump module size

2879,5 x 1147 mm

Gradeability | obstacles height

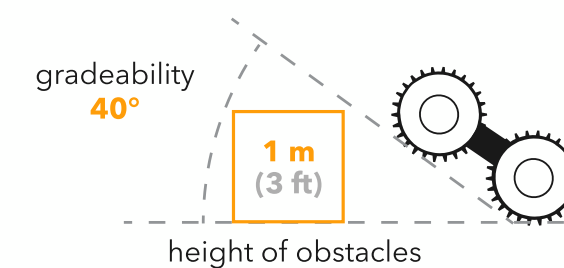

Power & Speed

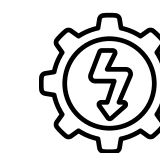

2 x 20 kWt engine

160 Nm torque

10 km/h speed

Loading capacity

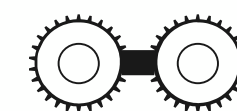

1200 kg
(2 645 lb)

Autonomy



4 hours

on a single charge
+ additional batteries

SHERP THE ARK

Unstoppable, unbeatable and reliable heavy utility vehicle.

SHERP the Ark is designed to carry both heavy cargos and groups of up to 22 people in the most extreme conditions. A powerful machine is presented in 2 options - universal cargo platform and people mover.



Safety

Digital inclinometer with sound and light alarm for critical tilt angles of the rear section

Rear-view camera

Unobstructed by terrain

SHERP the ARK all-wheel control system allows the driver to switch between different driving modes.

In case of necessity, the head unit drive can be turned off.

The rear section drive is ideal for moving over difficult terrains. In all-wheel control mode, the torque transmitted to the front and rear sections and provides better traction, safety, and handling.

Multi-power articulated steering

The Ark has an intuitive steering wheel control that features a 3-axis articulated steering system. It allows the driver to go over multi-level obstacles with ease.

The head unit of the Ark rises and rotates along 3 axis providing additional climbing capacity for difficult obstacles.

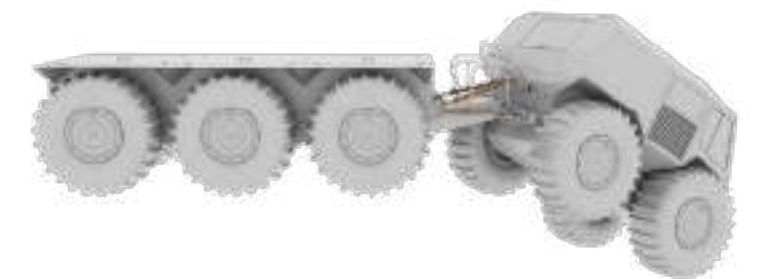

SHERP THE ARK. UNIVERSAL PLATFORM

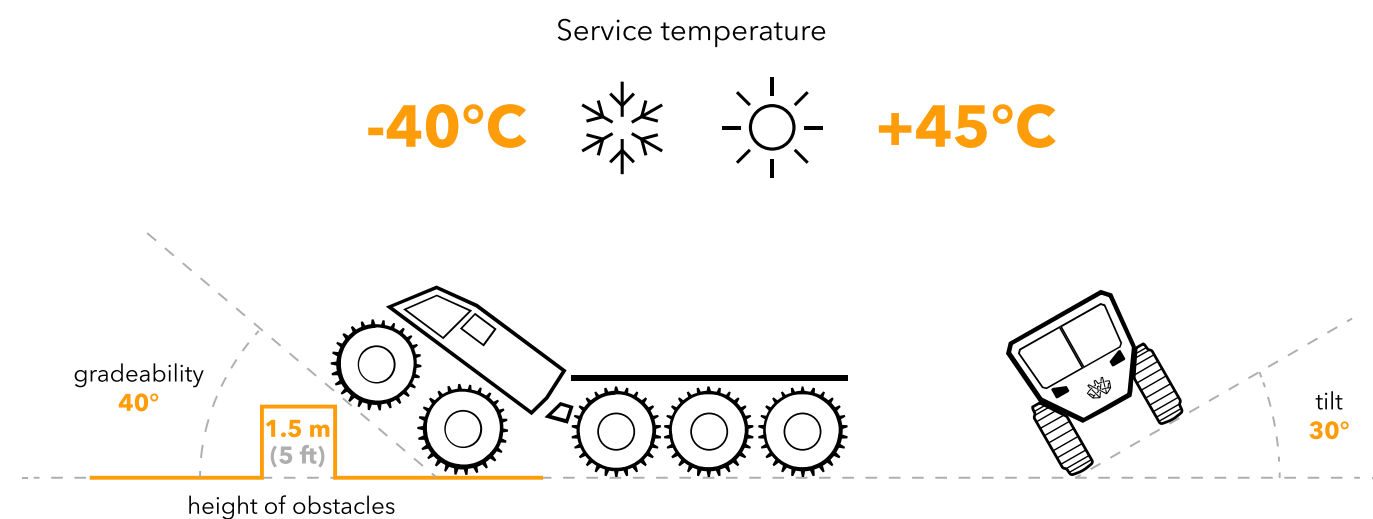

Overall dimensions

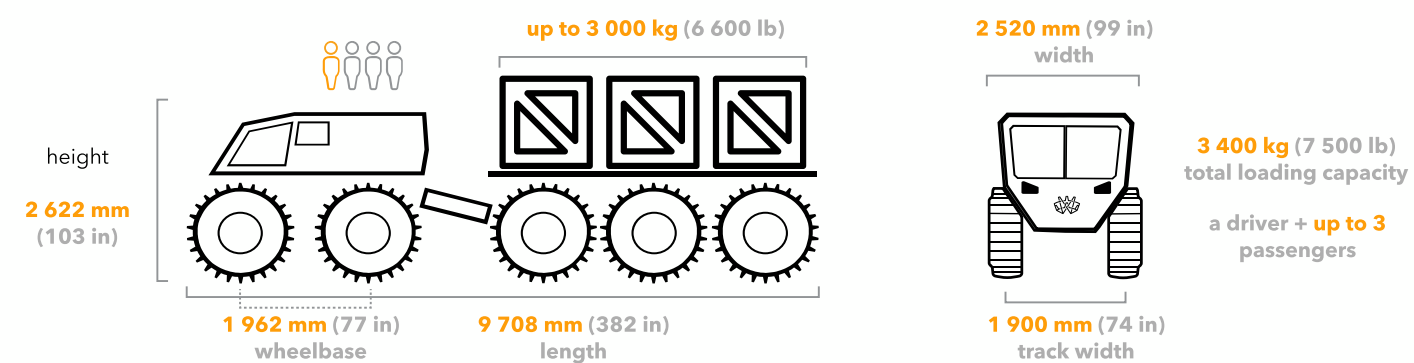

Fuel autonomy



180-760 L (47-200 gal)
8-12 lph (2-3 gph)

Fuel tank volume **180 L (47 gal)**
10 wheel fuel canisters **58 L (15.3 gal) each**
Up to **95 hours** of autonomy and **22 hours** of non-stop running with the main fuel tank.

Max. speed



Grounds

30 km/h (18.6 mph)

dense forests, fallen trees, shaky grounds, gravel, peatbog, moor, marsh, dunes, swamps, boulders, scree, snow, ice



Water

6 km/h (3,7 mph)

ponds, lakes, rivers, sandbanks, shelves, climbing from water onto the ice etc.

SHERP THE ARK. PEOPLE MOVER

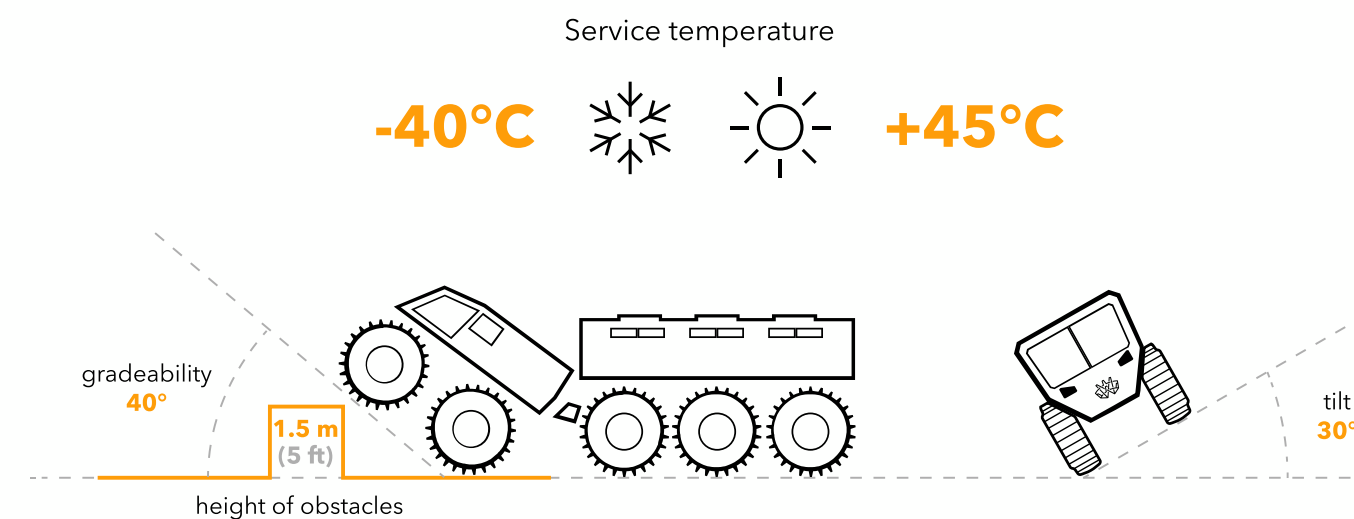

Overall dimensions

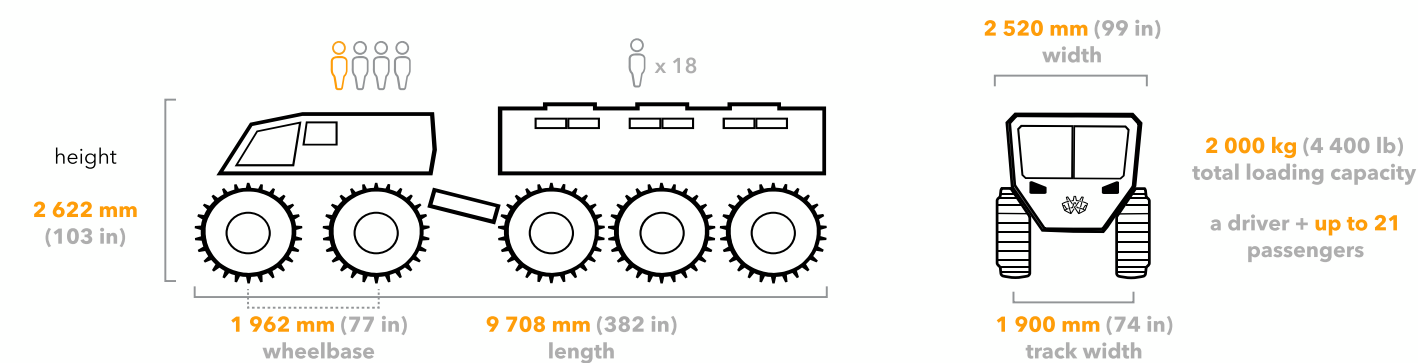

Fuel autonomy



180-760 L (47-200 gal)
8-12 lph (2-3 gph)

Fuel tank volume **180 L (47 gal)**
10 wheel fuel canisters **58 L (15.3 gal) each**
Up to **95 hours** of autonomy and **22 hours** of non-stop running with the main fuel tank.

Max. speed



Grounds

30 km/h (18.6 mph)

dense forests, fallen trees, shaky grounds, gravel, peatbog, moor, marsh, dunes, swamps, boulders, scree, snow, ice



Water

6 km/h (3,7 mph)

ponds, lakes, rivers, sandbanks, shelves, climbing from water onto the ice etc.



SHERP



📍 100, Stolychne Shosse str., Kyiv, Ukraine, 03026

✉ infoglobal@sherp.ua

🌐 <https://www.sherpglobal.com>